

CEW-151

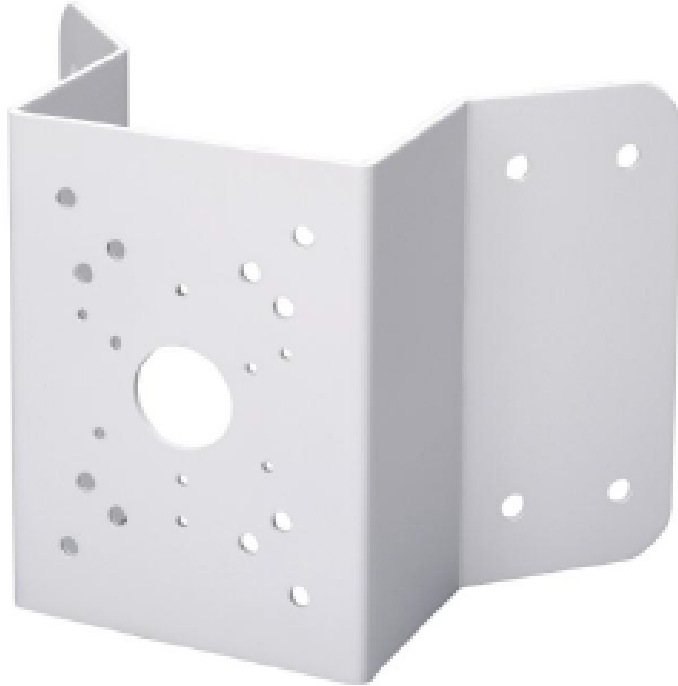

Features

- Material: SECC
- Corner Mount Bracket
- Neat & Integrated design

Dimensions (mm)

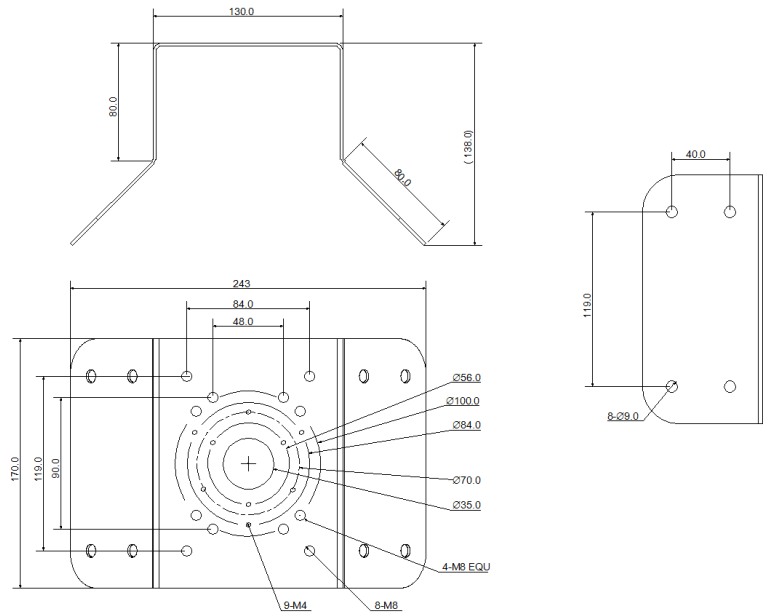

Specifications

Model	CEW-151
General	
Material	SECC
Dimension (W x H x D)	243mm x 170mm x 138mm
Pipe Thread	N/A
Operating Temperature	-40°C ~60°C
Humidity	0~90% RH
Load Bearing	10.0Kg
Weight	1.7Kg

Application

